

# MINI TCL SUPER



Antistrappo passivo  
Passive safety impac device  
Reißfest System passiv  
Anti choc passif  
Antichoque pasivo



- A** Ø 301 mm
- B** Ø 101 mm
- C** Ø 114 mm
- V** 57 m/sec

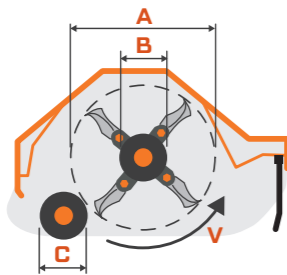

### Dotazioni di serie

- Attacco al trattore Cat.2
- Trasmissione a bagno d'olio con ruota libera
- Piedini di appoggio
- Rotore Bilanciato elettronicamente
- Rullo di appoggio autopulente regolabile in altezza
- Giunto cardanico
- Protezione Carter

### Standard equipment

- Tractor linkage Cat.2
- Oil sealed transmission with free wheel
- Rest
- Electronically balanced rotor
- Self cleaning supporting roller adjustable in height
- P.T.O. shaft
- Protecting carter

### Standardausstattung

- Traktoranbau Kat.2
- Ölbad-Getriebe mit Freilauf
- Stützfüße
- Rotor elektronisch ausgewuchtet
- Selbstreinigende, verstellbare Stützwalze mit Erdkratzer
- Gelenkwelle
- Anfahrtschutz mechanisch durch schwenkbaren Anbaubock
- Keilriemenschutz

### Équipement de série

- Attelage tracteur Cat.2
- Transmission bain d'huile avec roue libre
- Pieds d'appui
- Rotor équilibré électroniquement
- Rouleau d'appui auto nettoyant réglable en hauteur
- Cardan
- Protection carter

### Equipamiento estándar

- Conexión Cat. 2
- Transmisión con rueda libre
- Apoyos
- Rotor balanceado electronicamente
- Rodillo de apoyo autolimpiante y ajustable
- Junto cardán
- Protección carter

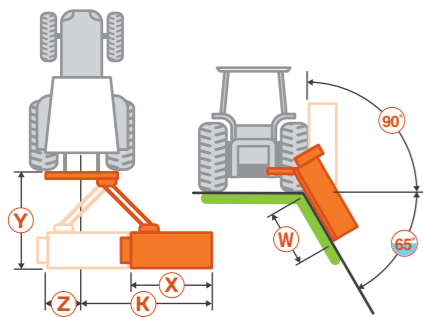

	X	Y	Z	K	W
	cm	cm	cm	cm	cm
MINI TCL Super 120	120	165	20	186	85
MINI TCL Super 140	140	165	20	206	106
MINI TCL Super 160	160	165	20	230	129

### Rullo regolabile - Adjustable roller



	A - B - C (mm)	mm - inch	G/min	CV - KW	N°	kg - lb	N°	N°	N°
MINI TCL Super 120	1635 - 1750 - 930	1200 - 47	540	40 - 29	3	265 - 585	40	20	20
MINI TCL Super 140	1940 - 1750 - 930	1400 - 55	540	50 - 36	3	290 - 640	48	24	24
MIN ITCL Super 160	2140 - 1750 - 940	1600 - 62	540	60 - 44	3	315 - 695	56	28	28

MINI TCL SUPER